

MULTI-FAMILY UNITS LOW VOLUME (M-1)

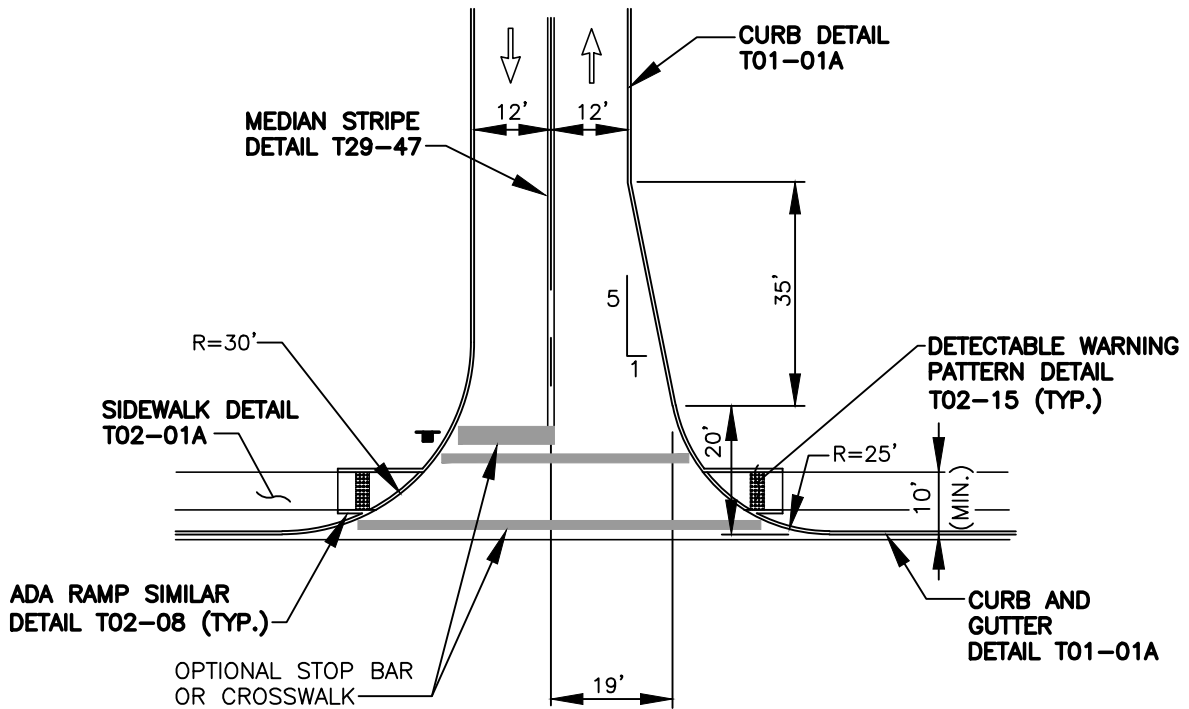

MULTI-FAMILY UNITS HIGH VOLUME (M-2)

NOTES:

1. MINIMUM DRIVE LENGTH IS 20 FEET, MEASURED FROM THE BACK OF SIDEWALK TO THE ENTRANCE OF THE OFF STREET PARKING AREA.
2. DIMENSIONS MAY VARY WITH ANALYSIS OF THE TURNING MOVEMENTS OF THE TYPICAL VEHICLE.

I:\CITYPPS\AUTOCAD\STD_DETAILS\DRAWING_FILES\T04-07

REV. NO.	DATE	BY	APPR	PUBLIC WORKS - STREETS AND TRANSPORTATION
1	3/06	RAW	MHA	
2	2/07	RAW	MHA	
3	8/08	RAW	MHA	
4	7/14	RAW	MHA	APPROVED BY: <i>M.H. Pedulla</i>
5	3/17	RAW	MHA	ENGINEER MANAGER
6	9/21	RAW	MHA	APPROVED DATE: 9/1/2021



RESIDENTIAL DRIVEWAYS	STANDARD PLAN NUMBER T04-07
-----------------------	--------------------------------