

**TWO-WAY INGRESS (CL-1)**

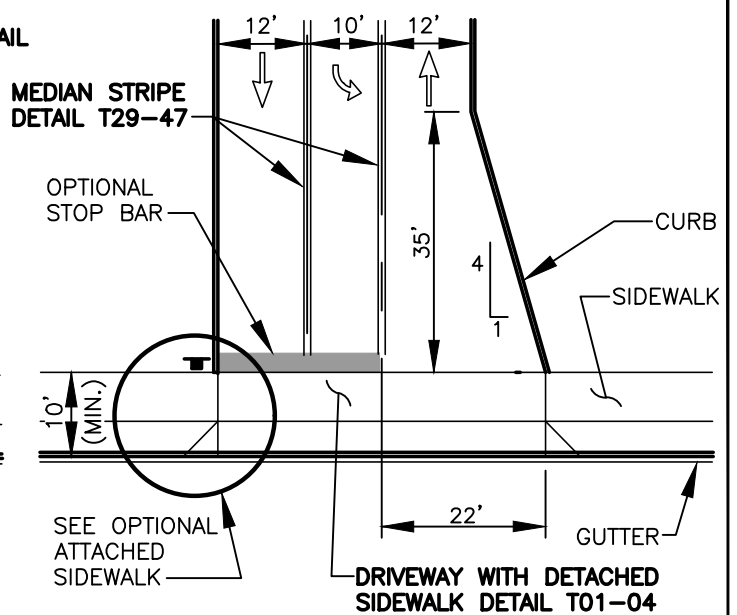

**TWO-WAY TWO EGRESS LANES (CL-2)**

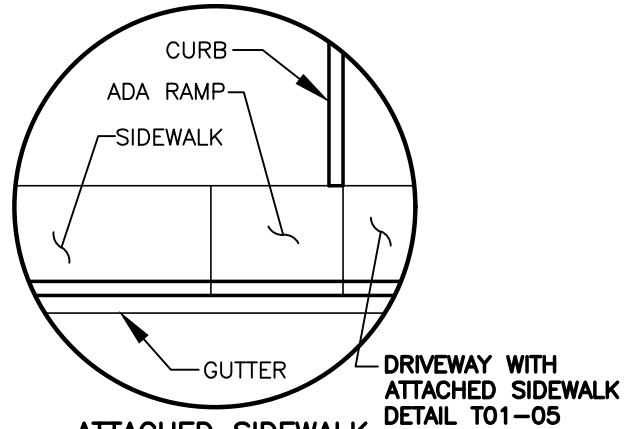

**ATTACHED SIDEWALK**

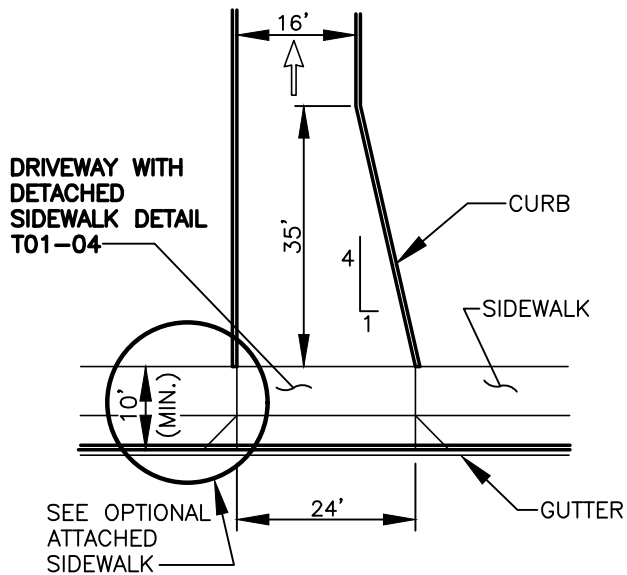

**ONE-WAY INGRESS (CL-3)**

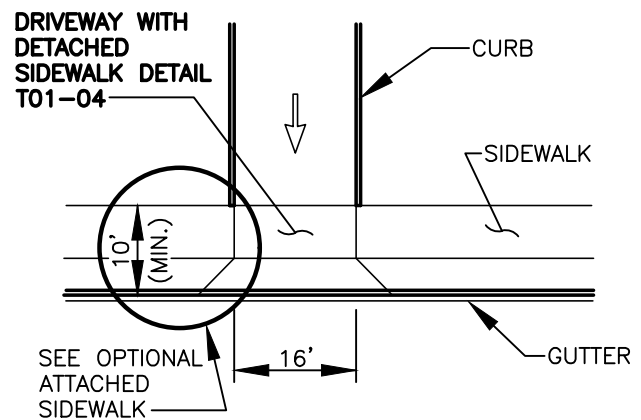

**ONE-WAY EGRESS (CL-4)**

**NOTES:**

1. MINIMUM DRIVE LENGTH IS 20 FEET, MEASURED FROM THE BACK OF SIDEWALK TO THE ENTRANCE OF THE OFF STREET PARKING AREA.
2. DIMENSIONS MAY VARY WITH ANALYSIS OF THE TURNING MOVEMENTS OF THE TYPICAL VEHICLE.

I:\CITYPPS\AUTOCAD\STD\_DETAILS\DRAWING\_FILES\T04-08

REV NO.	DATE	BY	APPR	PUBLIC WORKS - STREETS AND TRANSPORTATION
1	3/06	RAW	MHA	
2	2/07	RAW	MHA	
3	8/08	RAW	MHA	
4	7/14	RAW	MHA	
5	3/17	RAW	MHA	
6	9/21	RAW	MHA	

APPROVED BY: *M.H. Sedalla*  
ENGINEER MANAGER  
APPROVED DATE: 9/1/2021



COMMERCIAL/LOW VOLUME DRIVEWAYS	STANDARD PLAN NUMBER T04-08
---------------------------------	--------------------------------