

**SINGLE FUNCTION LUMINAIRE**

CONCRETE SHAFT

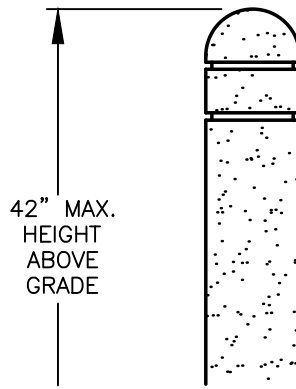

**BOLLARD**

CONCRETE SHAFT

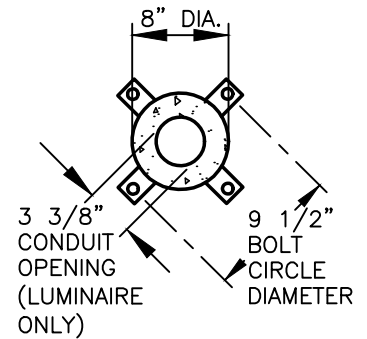

**BASE PLAN**

**NOTES:**

1. CERTIFICATION SHALL BE UNDERWRITERS LABORATORIES LISTED FOR 120 AND 240 VOLT WET LOCATIONS.
2. TOP CAP SHALL BE A ONE PIECE ALUMINUM CASTING 3/16" MINIMUM THICKNESS, SECURED TO LOUVERS BY CONCEALED ALLEN SCREWS IN KEYHOLE SLOTS. FOR RE-LAMPING ACCESS, ALLEN SCREWS SHALL NOT REQUIRE COMPLETE REMOVAL.
3. LOUVERS SHALL BE A ONE PIECE ALUMINUM CASTING WITH VERTICAL SUPPORT RIBS AT 90° INTERVALS. HORIZONTAL LOUVER BLADES SHALL HAVE A 1 3/4" DEPTH, A 65° UPWARD PITCH AND PROVIDE LIGHT SOURCE CUTOFF ABOVE HORIZONTAL. LOUVER CASTING SHALL BE SECURED TO SHAFT BY FOUR INTERNAL TIE RODS.
4. LAMP ENCLOSURE SHALL BE ONE PIECE TEMPERED MOLDED GLASS WITH INTERNAL FLUTES AND FULL GASKETING AT BOTTOM EDGE.
5. SOCKET SHALL BE PORCELAIN MEDIUM BASE RATED 4KV.
6. FIXTURE HEAD SHALL ALLOW FLOW-THROUGH VENTILATION AROUND AND ABOVE THE LAMP ENCLOSURE.
7. SHAFT CEMENT SHALL CONFORM TO CURRENT SPECIFICATIONS FOR "PORTLAND CEMENT." ASTM C150, TYPE I OR II. AGGREGATES SHALL MEET CURRENT REQUIREMENTS OF "SPECIFICATIONS FOR CONCRETE AGGREGATES," ASTM C33. WATER SHALL BE CLEAN AND FREE FROM DELETERIOUS AMOUNTS OF SILT, OIL, ACIDS, ALKALIES OR ORGANIC MATERIALS. WIRE FOR REINFORCEMENT SHALL CONFORM TO ASTM A185. STEEL FOR LUGS AND PLATES SHALL CONFORM TO ASTM A36, OR A283 GRADE D.
8. BALLAST SHALL BE HIGH POWER FACTOR FOR -20°F STARTING, FACTORY MOUNTED TO A RIGID HARNESS FOR FIELD WIRING AND SUSPENSION FROM FIXTURE WITHIN THE CONCRETE SHAFT.
9. ANCHOR BOLTS SHALL BE FOUR 3/8" X 10" + 2" ZINC PLATED L-HOOKS, EACH WITH TWO NUTS, WASHERS AND A RIGID PRESSED BOARD TEMPLATE.
10. FINISH SHALL BE T.G.I.C. THERMOSET POLYESTER POWDER-COAT PAINT APPLIED OVER A CHROMATE CONVERSION COATING. NATURAL GRAY SHALL BE USED FOR THE CONCRETE COLOR FINISH. LUMINAIRE FINISH SHALL BE BLACK.
11. SURFACE SHALL BE MEDIUM SAND-BLASTED WITH ANTI-GRAFFITI SEALER. COLOR SHALL BE NATURAL GRAY OR INTEGRAL IN CONCRETE MIX.
12. CURE AND STRENGTH SHALL ALLOW FOR COMPLETION OF THE HYDRATION PROCESS, AND RESULT IN A 28 DAY COMPRESSIVE STRENGTH OF NOT LESS THAN 4,500 PSI.
13. MANUFACTURE SHALL BE BY FIBERGLASS MOLDS TO INSURE UNIFORM PARTS. MOLD PARTING LINES MAY BE SLIGHTLY VISIBLE IN FINISHED PARTS.
14. ANCHORAGE SHALL BE BY FOUR STEEL MOUNTING TABS FOR INSTALLATION ON FOUR 1/2" X 10" + 2" ZINC ELECTROPLATED L-HOOK ANCHOR BOLTS. EACH ANCHOR BOLT IS SUPPLIED WITH TWO NUTS, TWO WASHERS, AND A RIGID PRESSED BOARD TEMPLATE.
15. ELECTRICAL MODULE SHALL BE 100 WATT COATED 120 LINE VOLTS, 129 LINE WATTS AND 1.15 MAX. AMPS.
16. SHIPMENT SHALL BE PALLETIZED WITH ADEQUATE HOLD-DOWNS TO PREVENT LOAD MOVEMENT IN TRANSIT.
17. **KIM LIGHTING MODEL. SEE CITY'S APPROVED PRODUCTS LIST FOR PART NUMBER.**
18. SEE **TYPICAL CONNECTING PUBLIC STREET WITH PATHWAYS AND LIGHTING DETAIL T07-03B** FOR ADDITIONAL INFORMATION.

I:\CITYPPS\AUTOCAD\STD\_DETAILS\DRAWING\_FILES\T07-03A

REV NO.	DATE	BY	APPR
1	2/07	RAW	CJC
2	8/08	RAW	CJC
3	2/07	RAW	CJC
4	4/18	RAW	CJC
5	9/21	RAW	CJC

**PUBLIC WORKS - STREETS AND TRANSPORTATION**

APPROVED BY: *[Signature]*  
TRAFFIC ENGINEER MANAGER  
APPROVED DATE: 9/1/2021



VANDAL RESISTANT  
BOLLARD (LIGHTED  
AND NON-LIGHTED)

STANDARD PLAN  
NUMBER

T07-03A