

TYPE PS

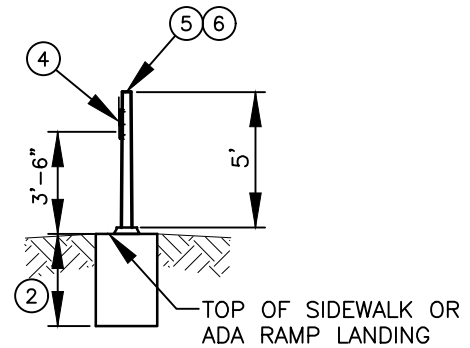

TYPE PPB

DRAFT
03/22/2022

NOTES:

- ① INSTALL PEDESTRIAN SIGNAL FACING TOWARD CENTER OF THE CROSSWALK. SEE **PEDESTRIAN SIGNAL HEAD OPTIONS DETAIL T20-09D** AND WSDOT STANDARD PLANS J-20.16-xx AND J-20.20-xx. WHEN MOUNTING TWO (2) PEDESTRIAN SIGNALS USE TYPE 1 POLE (STD. PLAN T20-04).
- ② SEE **TYPE PPB, TYPE PS AND TYPE I TRAFFIC SIGNAL POLE FOUNDATION DETAIL T20-16** AND SPECIFICATIONS FOR FOUNDATION INFORMATION.
- ③ PROVIDE COVERED HAND HOLE.
- ④ INSTALL **ADA PEDESTRIAN AUDIBLE PUSH BUTTON ASSEMBLY** WITH ARROW POINTING TOWARD THE CROSSWALK. SEE **STANDARD PLANS T20-09B AND T20-09E**. SEE PLANS FOR ORIENTATION.
- ⑤ TOP OF POLE SHALL BE COVERED WITH POLE CAP.
- ⑥ TYPE PPB STANDARD POLE. SEE WSDOT STANDARD PLANS J-20.10 AND J-20.11.
- ⑦ TYPE PS STANDARD POLE. SEE WSDOT STANDARD PLANS J-20.11, J-20.16 AND J-21.10.

I:\CITYPPS\AUTOCAD\STD_DETAILS\DRAWING_FILES\T20-05

REV NO.	DATE	BY	APPR	AGE
1	7/14	RAW	AGE	
2	8/14	RAW	CJC	
3	7/19	RAW	CJC	
4	2/21	RAW	CJC	
5	9/21	RAW	CJC	
6	3/22	RAW	CJC	

PUBLIC WORKS – STREETS AND TRANSPORTATION

APPROVED BY: *[Signature]*
TRAFFIC ENGINEER MANAGER

APPROVED DATE: 3/22/2022



TYPE PS AND TYPE PPB TRAFFIC SIGNAL STANDARD	STANDARD PLAN NUMBER T20-05
---	-----------------------------------