

CONSTRUCT 6" WIDE (NOMINAL) STD. VERTICAL CURB (GRADE CORRECTION CURB) WHERE SHOWN ON PLANS

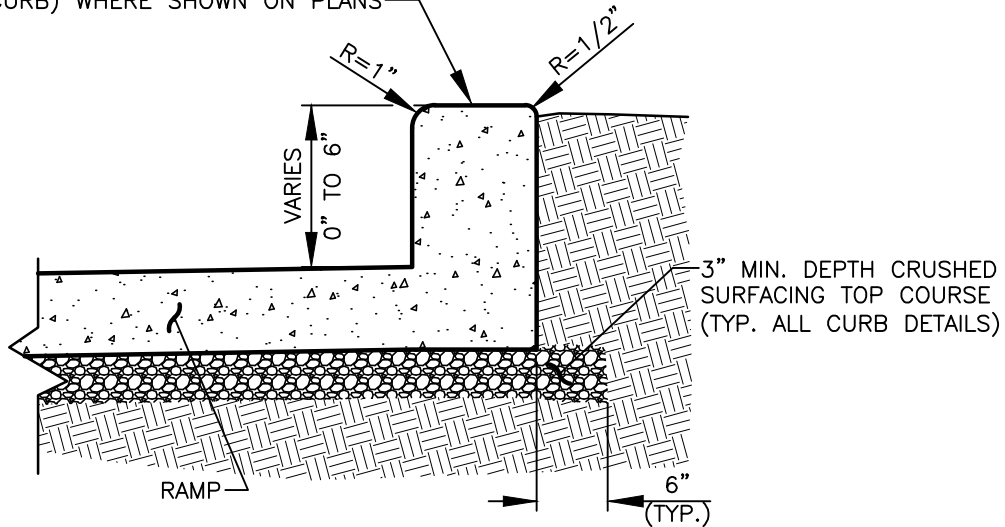

MONOLITHIC CURB AND ADA RAMP

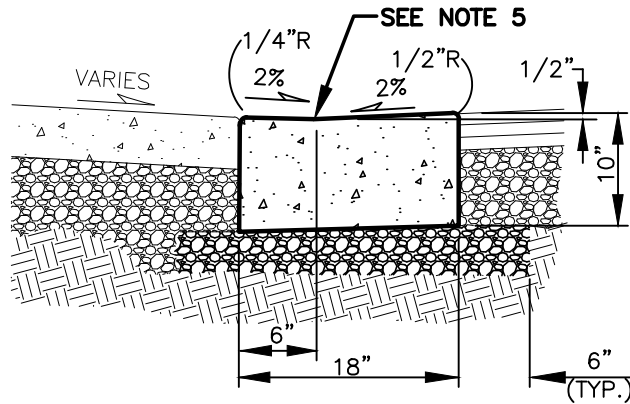

CURB AND GUTTER AT ADA RAMP

NOTES:

1. CONCRETE CURBS SHALL BE 3000 PSI MIN. (CL 3000), 3-1/2" SLUMP (MAX.).
2. TOOLED JOINTS ARE REQUIRED AT ALL SIDEWALK RAMP SLOPE BREAK LINES.
3. WHERE ADA RAMP REQUIRES GRADE CORRECTION CURB (BACK OR SIDES), CONSTRUCT CURB AND RAMP AS MONOLITHIC POUR. CURB ALONG ROADWAY OR PARKING LOT TO BE SEPARATE CURB POURS.
4. CURBS ADJACENT TO PAVEMENT OR SIDEWALK SHALL HAVE EXPANSION AND/OR CONSTRUCTION JOINTS TO MATCH EXISTING PATTERNS. 3/8" EXPANSION JOINTS SHALL BE PLACED ON BOTH SIDES OF CATCH BASINS, AT TOPS OF DRIVEWAYS, ALL CHANGES IN DIRECTION, AND AS DIRECTED BY THE INSPECTOR. CONTRACTION JOINTS TO BE PLACED AT 15' MAXIMUM SPACING.
5. FOR CURB DROPS AT ADA RAMP ZERO LIP FROM FLOW LINE, SEE **RAMP LIP, DRIVEWAY LIP AND DETECTABLE WARNING PATTERN DETAIL T02-15**.
6. COMPACT SUBGRADE AND CRUSHED SURFACING TOP COURSE TO 95% MAXIMUM DRY DENSITY (3" MIN. DEPTH).
7. SEE **PAVEMENT RESTORATION/WIDENING AT CURBS DETAIL T05-01A**.
8. CURB TO BE MEDIUM BROOM FINISHED, PARALLEL TO GUTTER LINE.
9. WHERE MATCHING EXISTING CURBS, ALL EXISTING EDGES SHALL BE SAWCUT.
10. WHEN ATTACHED SIDEWALKS ARE USED WITH ROLLED CURB AND GUTTER, THICKENED SIDEWALKS (6" MIN.) SHALL BE CONSTRUCTED UNDER THE SAME CONSTRUCTION CONTRACT.

I:\CITYAPPS\AUTOCAD\STD_DETAILS\DRAWING_FILES\T01-01B.DWG

 CITY OF Vancouver WASHINGTON	ADA RAMP CURBS			STD. PLAN NO. T01-01B			
	CITY OF VANCOUVER DEPARTMENT OF PUBLIC WORKS TRANSPORTATION DIVISION				DRAWN BY CDC	APPROVED BY <i>M.H.H.</i>	APPROVAL DATE 3/17
	CITY OF VANCOUVER DEPARTMENT OF PUBLIC WORKS TRANSPORTATION DIVISION				REVISION 4	APPROVED BY <i>M.H.H.</i>	APPROVAL DATE 3/24