

* 1.5% OR FLATTER RECOMMENDED FOR DESIGN/FORMWORK (2% MAX.)

SECTION A-A

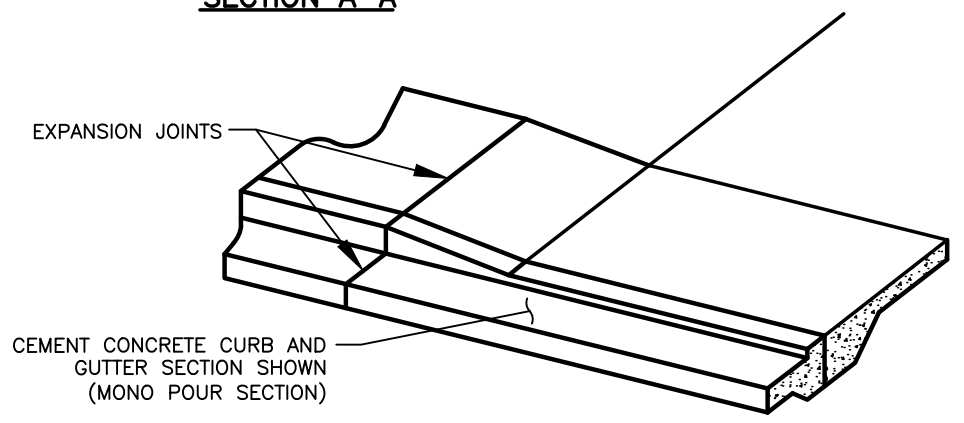

HALF ISOMETRIC

NOTES:

1. CONCRETE SHALL BE CLASS 4000 MIN.
2. CURB TO BE BRUSHED FINISHED. ALL EXISTING EDGES SHALL BE SAWCUT.
3. 1/2" VERTICAL LIP ACROSS APPROACH.
4. SUBGRADE SHALL BE COMPACTED TO 95% MAX DRY DENSITY.
5. MIN. 3" DEPTH CSBC, COMPACTED TO 95% OF MAX DRY DENSITY.
6. SEE **STANDARD DETAIL T05-02** FOR CONCRETE JOINTS.

I:\CITYAPPS\AUTOCAD\STD_DETAILS\DRAWING_FILES\T01-06.DWG



CONCRETE DRIVEWAY CUT DETAIL				STD. PLAN NO.
CITY OF VANCOUVER DEPARTMENT OF PUBLIC WORKS TRANSPORTATION DIVISION	DRAWN BY CDC	APPROVED BY <i>M.H.H.</i>	APPROVAL DATE 2/21	T01-06
	REVISION 3	APPROVED BY <i>M.H.H.</i>	APPROVAL DATE 3/24	