

NOTES:

1. EXISTING CURB AND SIDEWALK TO BE SAWCUT AND REMOVED FOR INSTALLATION OF NEW RAMP.
2. RAMP MAY BE USED MID BLOCK OR ON INTERSECTION RADIUS.
3. RAMP TO BE CENTERED IN CROSSWALK.
4. RAMPS TO BE CONSTRUCTED SEPARATELY FROM SIDEWALK, AND ISOLATED BY EXPANSION JOINT MATERIAL.
5. FOR SECTIONS A-A AND B-B, SEE **STANDARD LANDING CROSS SECTIONS - A-A AND B-B DETAIL T02-11.**
6. AT THE TOP OF EACH RAMP A 5'X5' LANDING AREA SHALL BE CONSTRUCTED AND THE LONGITUDINAL CROSS SLOPE SHALL NOT EXCEED 2% *EACH DIRECTION.
7. IF THE MAXIMUM SLOPE OF 8.3% **CANNOT BE ACHIEVED DUE TO THE SLOPE OF THE EXISTING SIDEWALK, THE LENGTH OF THE CURB RAMP SHALL NOT BE REQUIRED TO BE LONGER THAN 15 FEET REGARDLESS OF THE RESULTING RAMP SLOPE.
8. RAMP CROSS SLOPE SHALL BE 2% *MAXIMUM.
9. TYPE A-1 AND E-1 CURB (SEE **CONCRETE CURBS DETAIL T01-0A1**) POURED SEPARATELY FROM RAMPS.
10. **ADA RAMP AND GRADE CORRECTION CURBS** POURED MONOLITHICALLY.
11. ALL RAMPS IN AREAS ZONED CITY CENTER OR WHERE THE HERITAGE SIDEWALK IS CONSTRUCTED ARE REQUIRED TO BE CONSTRUCTED WITH BRICK UNIT PAVERS, SEE **BRICK UNIT PAVER PATTERN T02-16** FOR BRICK LAYOUTS.

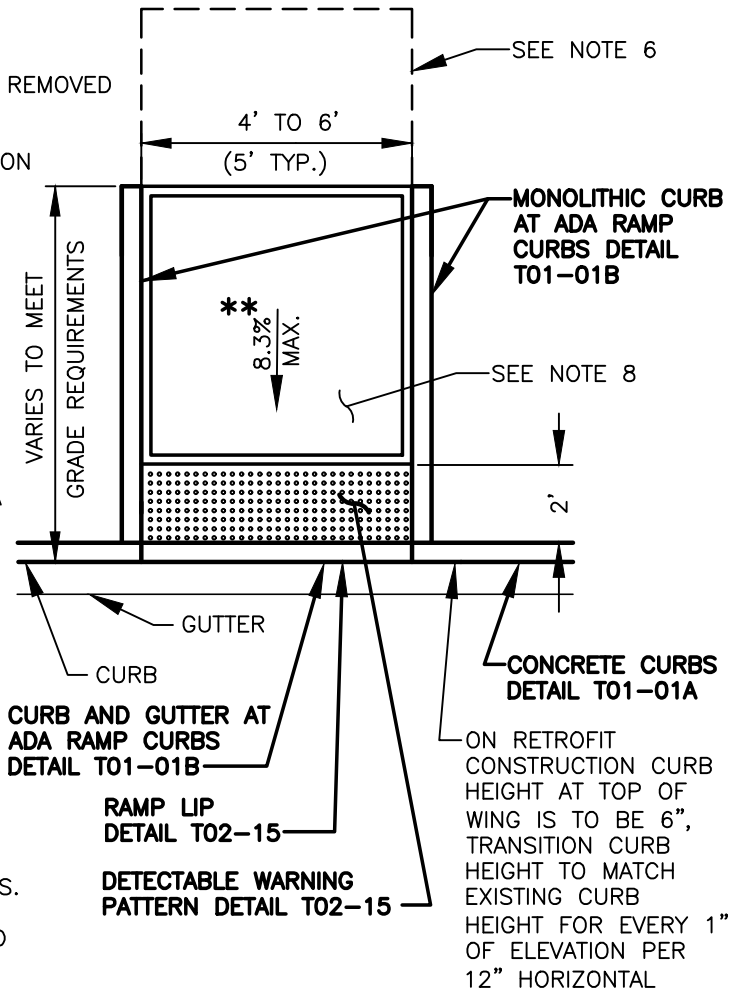

* 1.5% OR FLATTER RECOMMENDED FOR DESIGN/FORMWORK (2% MAX.)
 ** 7.5% OR FLATTER RECOMMENDED FOR DESIGN/FORMWORK (8.3% MAX.)

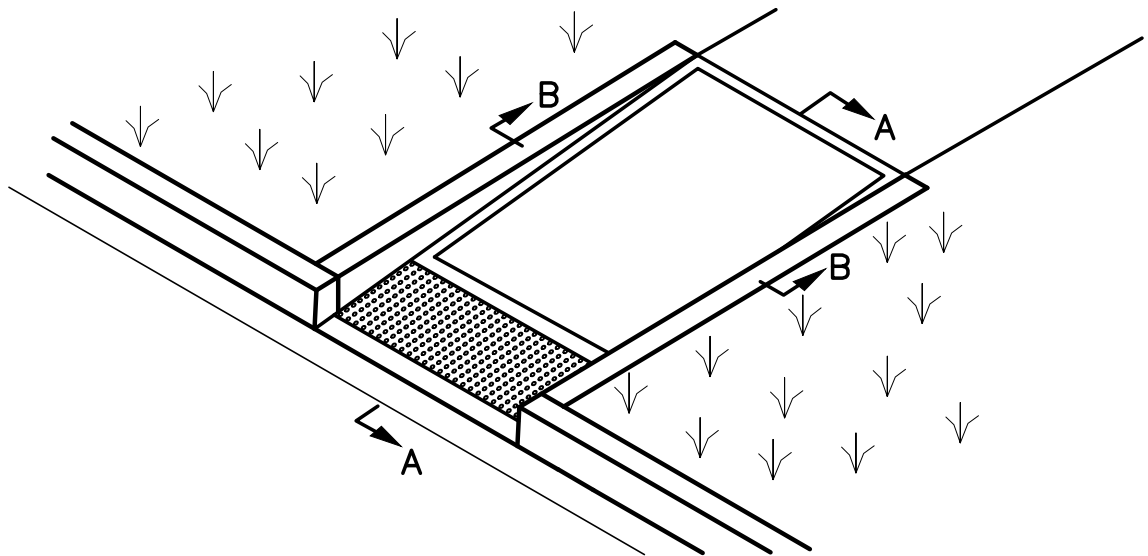

PERPENDICULAR RAMP CONSTRUCTION



CITY OF VANCOUVER
 DEPARTMENT OF PUBLIC WORKS
 TRANSPORTATION DIVISION

DRAWN BY	APPROVED BY	APPROVAL DATE
CDC	<i>M.H.H.</i>	8/04
REVISION	APPROVED BY	APPROVAL DATE
7	<i>M.H.H.</i>	3/24

STD. PLAN NO.
T02-08