

TRUNCATED DOMES COLOR SCHEME

LOCATION	COLORS
ALL BRICK RAMPS	WHITE
STREETS WITH A MAJORITY OF RESIDENTIAL FRONTAGE	BRICK RED
NON-RESIDENTIAL ARTERIAL STREETS	SAFETY YELLOW

	MIN.	MAX.
A	1 5/8"	2 3/8"
B	2/3"	1 1/2"
C	7/16"	3/4"
D	7/8"	1 7/16"

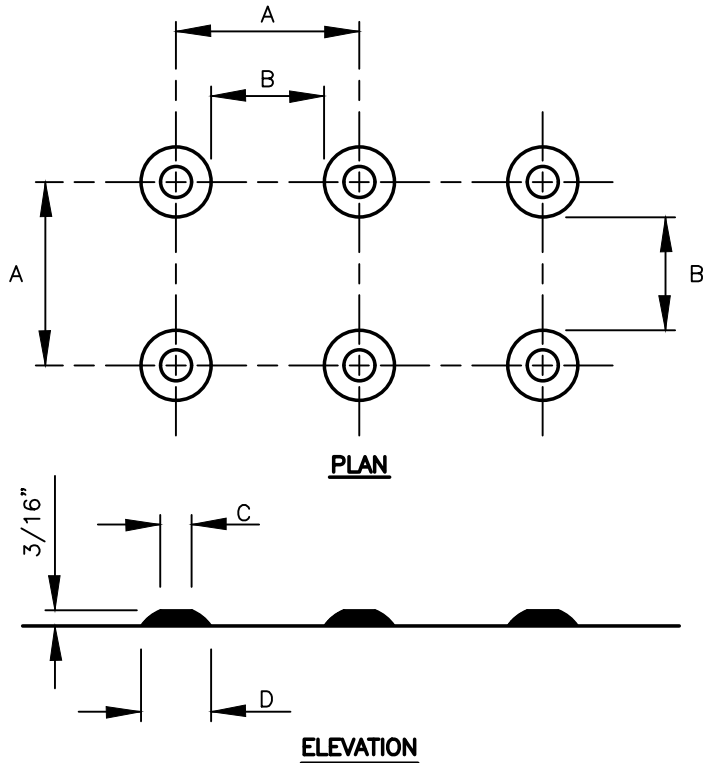

NOTES:

1. MANUFACTURERS SHALL MEET THE REQUIREMENTS LISTED UNDER THE CONTRACT SPECIAL PROVISIONS AND MUST BE ON THE CITY OF VANCOUVER'S APPROVED PRODUCT LIST. THE PRODUCT LIST IS TAKEN FROM WSDOT PRODUCT LIST, THAT IS UPDATED PERIODICALLY.
2. DETECTABLE WARNINGS SHALL BE MANUFACTURED USING THE MATERIALS SPECIFIED ON THE PLAN SHEETS WITH THE DOME DIMENSIONS AND SPACING SHOWN AND INSTALLED PER THE MANUFACTURER'S RECOMMENDED PROCEDURES.
3. DETECTABLE WARNINGS SHALL BE INSET INTO NEW CONCRETE. GLUED ON OR NAILED DOWN PRODUCTS ARE NOT ACCEPTABLE FOR NEW CONSTRUCTION.
4. ANY VARIATION FROM THE CITY DETECTABLE WARNING POLICY REQUIRES APPROVAL FROM THE DIRECTOR.
5. SAFETY YELLOW TRUNCATED DOMES ARE RECOMMENDED IN SCHOOL ZONES AND ALONG SCHOOL ROUTES.

DETECTABLE WARNING PATTERN DETAIL



RAMP LIP, DRIVEWAY LIP, AND DETECTABLE WARNING PATTERN

CITY OF VANCOUVER
DEPARTMENT OF PUBLIC WORKS
TRANSPORTATION DIVISION

DRAWN BY	APPROVED BY	APPROVAL DATE
CDC	<i>M.H.H.</i>	8/04
REVISION	APPROVED BY	APPROVAL DATE
7	<i>M.H.H.</i>	3/24

STD. PLAN NO.
T02-15