

TWO-WAY INGRESS (CL-1)

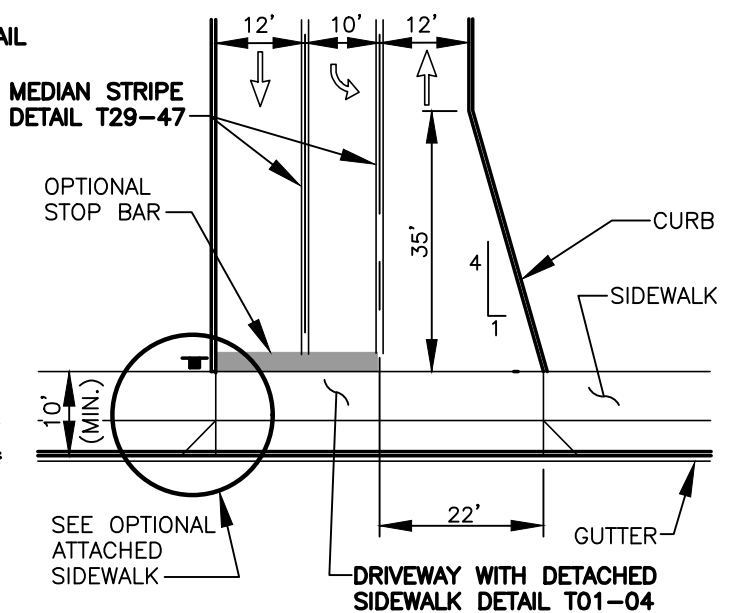

TWO-WAY TWO EGRESS LANES (CL-2)

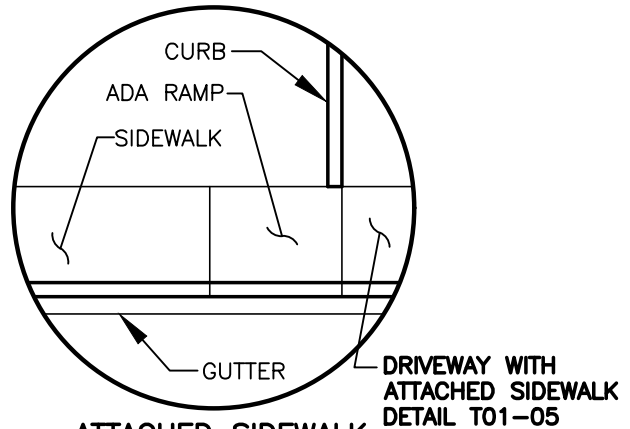

ATTACHED SIDEWALK

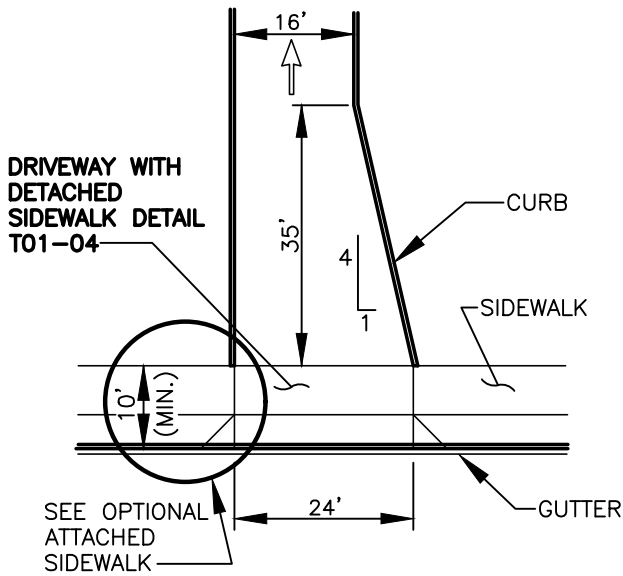

ONE-WAY INGRESS (CL-3)

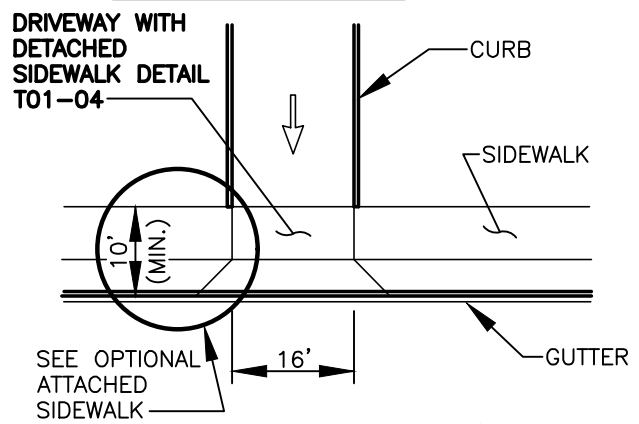

ONE-WAY EGRESS (CL-4)

NOTES:

1. MINIMUM DRIVE LENGTH IS 20 FEET, MEASURED FROM THE BACK OF SIDEWALK TO THE ENTRANCE OF THE OFF STREET PARKING AREA.
2. DIMENSIONS MAY VARY WITH ANALYSIS OF THE TURNING MOVEMENTS OF THE TYPICAL VEHICLE.

I:\CITYAPPS\AUTOCAD\STD_DETAILS\DRAWING_FILES\T04-08.DWG



COMMERCIAL / LOW VOLUME DRIVEWAYS

CITY OF VANCOUVER
DEPARTMENT OF PUBLIC WORKS
TRANSPORTATION DIVISION

DRAWN BY	APPROVED BY	APPROVAL DATE
CDC	<i>M.H.H.</i>	8/04
REVISION	APPROVED BY	APPROVAL DATE
7	<i>M.H.H.</i>	3/24

STD. PLAN NO.
T04-08