

**LEGEND:**

④ ORDER OF WORK.

**EXISTING TYPE E-1 CURB**

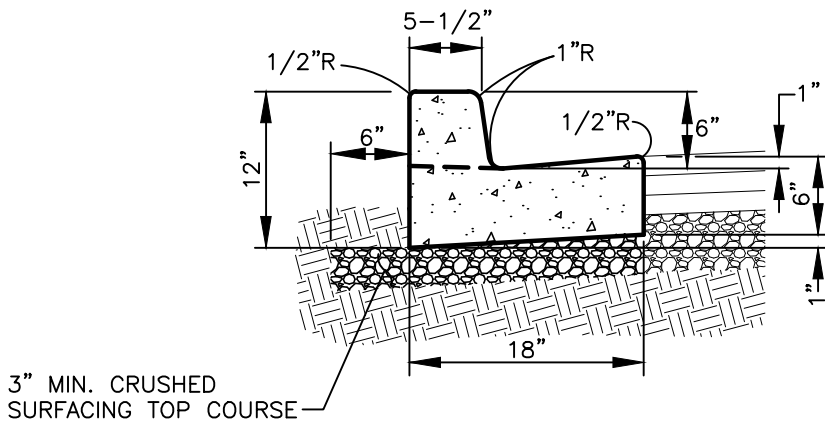

**⑤ PROPOSED TYPE A-1 CURB AND GUTTER**

(FOR ADDITIONAL INFORMATION SEE CONCRETE CURB DETAIL T01-01A)

**NOTES:**

1. IF HMA IS DAMAGED OR UNDERMINED WHILE REMOVING EXISTING CURB, SAWCUTTING AND PAVEMENT RESTORATION IS REQUIRED, SEE **RESTORATION/WIDENING AT CURBS DETAIL T05-01A** AND **PAVEMENT RESTORATION LIMITS DETAIL T05-01B**.
2. COMPACT SUBGRADE AND CRUSHED SURFACING TOP COURSE TO 95% OF MAXIMUM DRY DENSITY (3" MIN. DEPTH).



**OPTIONAL E-1 CURB REPLACEMENT WITH A-1 CURB AND GUTTER**

CITY OF VANCOUVER  
DEPARTMENT OF PUBLIC WORKS  
TRANSPORTATION DIVISION

DRAWN BY	APPROVED BY	APPROVAL DATE
CDC	<i>M.H.H.</i>	8/08
REVISION	APPROVED BY	APPROVAL DATE
6	<i>M.H.H.</i>	3/24

STD. PLAN NO.  
**T05-14**