

ADJUSTABLE
OVERHEAD MAST
ARM SWING SIGN
BRACKET

2-6' LONG SHAPED
ALUM. STIFFENER
BARS (SAME LENGTH
ALL SIGNS)

STRAP (2) 3/4" STAINLESS .030 BANDING
STRAPS (2000 LBS STRENGTH EACH STRAP)
USE BANDING CLIPS (2 STRAPS)

OVERHEAD MAST ARM
SWING SIGN BRACKET

SUFFIX

PREFIX

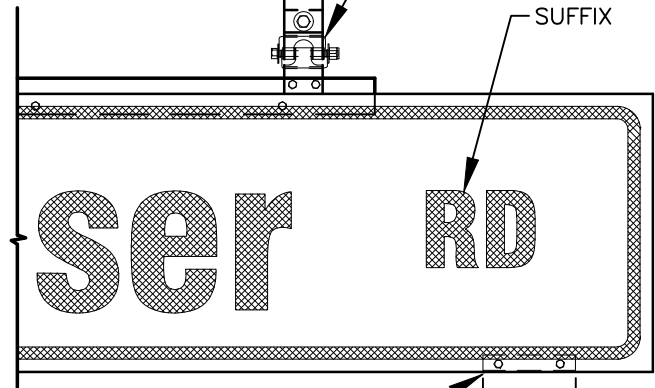
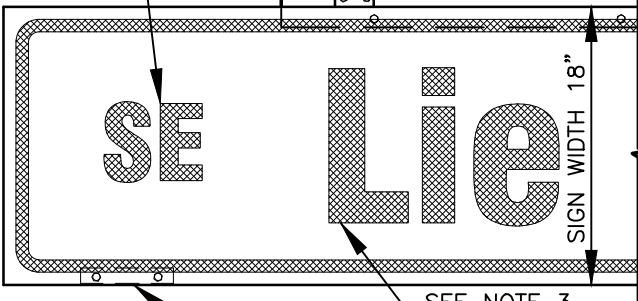

SIGN LENGTH 6' - 10' (VARIES)

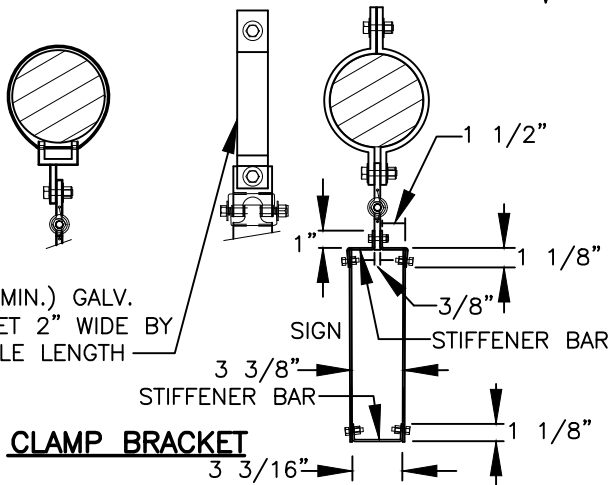

1/4" (MIN.) GALV.
BRACKET 2" WIDE
BY VARIABLE
LENGTH

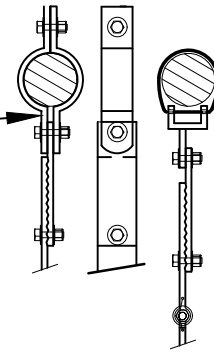

CLAMP BRACKET STRAP

NOTES:

1. STREET NAME SIGN SHALL BE MADE OF .125 ALUMINUM SHEETING, FLAT STOCK, 18" WIDE BY 6' TO 10' IN LENGTH, (IN 6" INCREMENTS).
2. SIGN FACE SHALL BE FABRICATED FROM CUBED CORNERED LENS (VIP, TYPE A) REFLECTIVE MATERIAL. FACE LEGEND AND BORDER SHALL BE WHITE ON A GREEN BACKGROUND, EXCEPT IN THE DOWNTOWN AREA, WHICH SHALL HAVE A BROWN BACKGROUND.
3. LETTERING SHALL BE A COMBINATION OF UPPER AND LOWER CASE LETTERS PER FHWA STANDARDS. CAPITAL LETTERS OF THE STREET NAME SHALL BE 12" HEIGHT, EXCEPT WHEN TWO LINES ARE REQUIRED, THEN THE LETTERS SHALL BE 10" HEIGHT. THE PREFIX AND SUFFIX SHALL BE ABBREVIATED UPPER CASE LETTERS 6" HEIGHT, EXCEPT WHEN TWO LINES OF COPY ARE REQUIRED, THEN THE LETTERS SHALL BE 5" HEIGHT.
4. STIFFENER BARS SHALL BE .125 ALUMINUM SHAPED TO DIMENSIONS ABOVE.
5. COMPLETE READY-TO-MOUNT STREET NAME SIGN ASSEMBLY NOT TO EXCEED 65 POUNDS IN WEIGHT.
6. ALL SIGN MATERIALS AND ATTACHMENT HARDWARE SHALL CONFORM TO MUTCD AND WSDOT STANDARD SPECIFICATIONS.
7. WHEN SIGN REQUIRES TWO MESSAGE LINES, WIDTH SHALL BE INCREASED TO 30" AND AN ARROW SHALL BE ADDED TO BOTH MESSAGE LINES (LEFT ARROW LEFT OF THE DIRECTION AND RIGHT ARROW ON THE RIGHT).
8. ENGINEER SHALL APPROVE FACE COPY PRIOR TO FABRICATION.

**OVERHEAD STREET NAME SIGN
MOUNTING AND FABRICATION**



CITY OF VANCOUVER
DEPARTMENT OF PUBLIC WORKS
TRANSPORTATION DIVISION

DRAWN BY	APPROVED BY	APPROVAL DATE
CDC		8/04
REVISION	APPROVED BY	APPROVAL DATE
7		3/24

STD. PLAN NO.

T20-07