



## THE CITY OF PORTLAND

The ever-classic "Staple" style bike rack is Portland City Code approved with an internal cable and flat bar for extra security. Lock it up!

### CONSTRUCTION/MATERIAL OPTIONS

- 1.5" Sch. 40 Round Steel Pipe
- 2" x 2" Square Steel Tubing (Inset, Pipecutter Proof)

- Steel Flanges
- Steel Flat Bar

### DIMENSIONS

- 30" Length
- 6" Width
- 35" Height
- Custom Size Height/Length

### MOUNTING OPTIONS

- Flange Mount (Shown)
- (6) .63" Mounting Holes
- In-Ground
- 11" Leg Extensions

### FINISH OPTIONS

- T304 Stainless Steel
- #4 Satin Finish
- Hot Dipped Galvanized
- Powder Coating
- # \_\_\_\_\_
- Thermoplastic Coating
- # \_\_\_\_\_

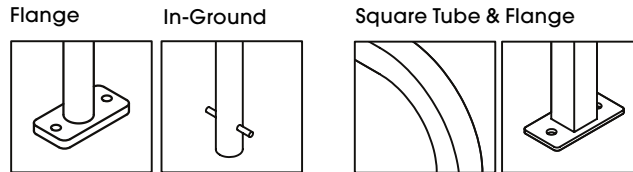
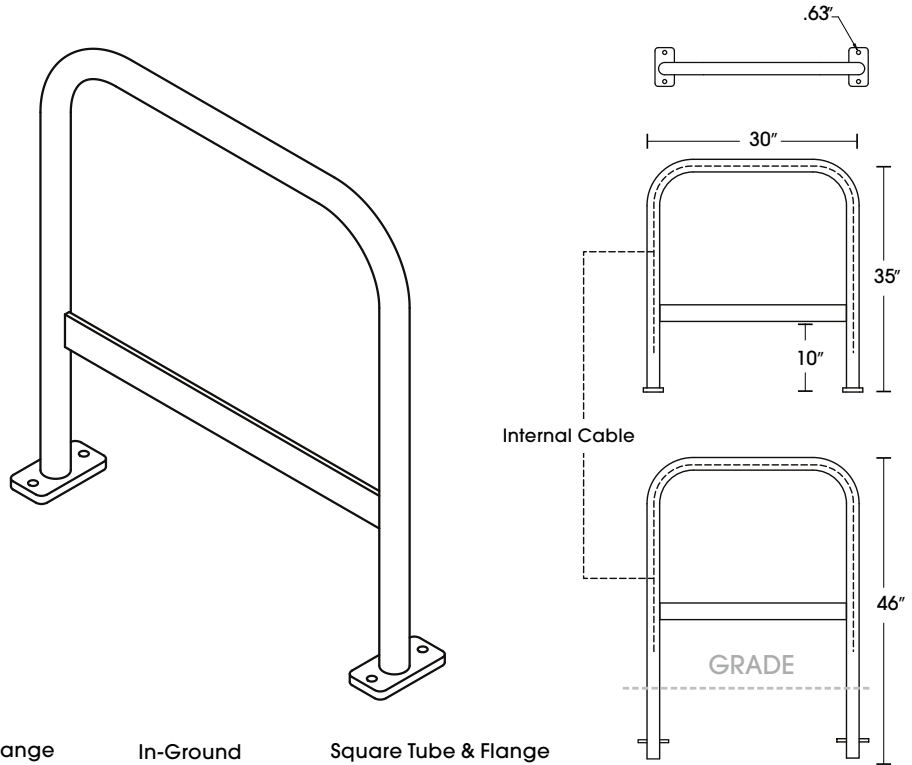

### RECOMMENDED LAYOUT

#### NOTES:

- "Bike" is 70"
- # Minimum Spacing
- (#) Recommended Spacing

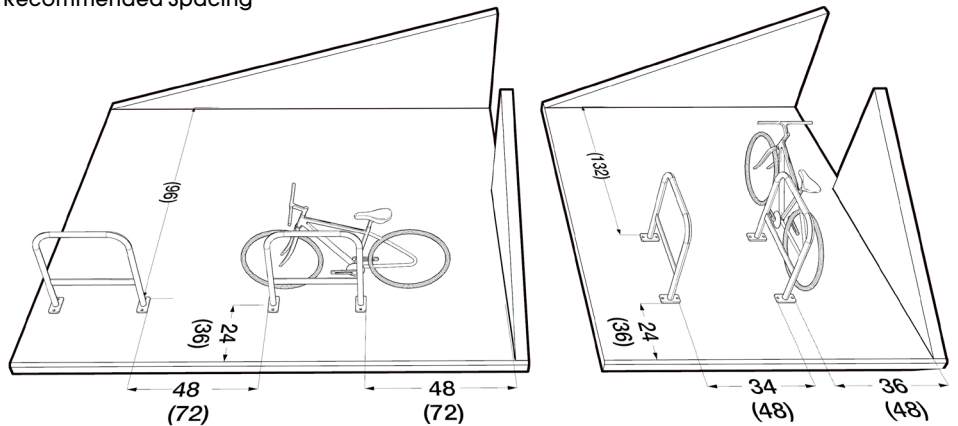

CONTRACTOR: \_\_\_\_\_

JOB: \_\_\_\_\_

NOTES: \_\_\_\_\_